



Operating Instructions MA 42

TABLE OF CONTENTS

WARRANTY	1
1.0 SPECIFICATIONS.....	2
2.0 INTRODUCTION.....	5
2.1 Instrument Description	5
3.0 UNPACKING AND INSPECTION.....	6
3.1 External Inspection.....	6
3.2 Unpacking	6
3.3 Accessories Supplied	6
4.0 FRONT AND REAR PANEL CONTROLS AND DESCRIPTIONS.....	7
4.1 Front Panel Controls	7
4.2 Rear Panel Controls.....	11
5.0 INSTALLATION AND SETUP	12
5.1 Headset/Insert Phones.....	12
5.2 Bone Conduction Transducer	12
5.3 Monitor/Microphone Headset	12
5.4 Patient Response Switch	12
5.5 Sound Room Patch Cords - Optional	12
5.6 Tape/CD Player - Optional	13
5.7 Speakers - Optional.....	13
6.0 VOLTAGE AND POWER REQUIREMENTS.....	14
7.0 OPERATION - PURE TONE AUDIOMETRY	15
7.1 Air Conduction Testing	15
7.2 Bone Conduction Testing	16
7.3 Masking	16
7.4 Stenger Test	16



Operating Instructions MA 42

8.0	OPERATION - SPEECH AUDIOMETRY	17
8.1	Calibrating CD or Tape Speech Test Material	17
8.2	Calibrating the Microphone for Live Speech Testing	17
8.3	Talk-Back Microphone and Monitor Headset	17
8.4	Monitor Speaker	17
8.5	Speech Testing	18
8.6	MCL (Most Comfortable Level) Procedure	18
8.7	UCL (Uncomfortable Loudness Level) Procedure	18
9.0	MASTER HEARING AID	19
10.0	NOAH INSTALLATION INSTRUCTIONS	20
10.1	Maico Audiogram Module Installation	20
10.2	Activating the Audi-Link Driver	20
10.3	Transferring SRT, MCL and UCL Information on the MA 42	20
11.0	MAINTENANCE	21
11.1	Preventive Maintenance	21
11.2	Cleaning the MA 42	21
11.3	Calibration	22
11.4	Shipping Instructions for Calibration and Repair	23



Operating Instructions MA 42

WARRANTY

This warranty is extended to the original purchaser of the MA 42 Portable Diagnostic Audiometer with Master Hearing Aid by Maico, through the authorized Special Instrument Distributor from whom it was purchased. This warranty covers defects in material and workmanship for a period of one year from date of delivery of the MA 42.

Should the Maico MA 42 require service due to a defect in material or workmanship, Maico, at its option, will repair or replace the instrument at no charge except for transportation to and from the point of service. It is the purchaser's responsibility to return the MA 42 to the Maico Special Instrument Distributor from whom it was purchased or directly to Maico after receiving a return authorization.

This warranty does not cover breakage or failure caused by tampering, misuse, carelessness, accident or modification. The warranty is void if the instrument is serviced by other than an authorized Maico Special Instrument Service Center.

NOTE:

Specifications in this manual are in effect at the time of printing. Maico reserves the right to modify or change specifications or design at any time without notice or incurring obligation.

WARNING:

The Maico MA 42 is designed to be used with a hospital grade outlet. Injury to personnel or damage to equipment can result when a three-prong to two-prong adapter is connected between the power plug and an AC outlet or extension cord.



Operating Instructions MA 42

1.0 SPECIFICATIONS

Test signals: Pure tone, pulsed, warble; narrow band and speech masking noise with two channels

Frequency accuracy: To within $\pm 1\%$ maximum of indicated frequency

Frequency and HL ranges:

Frequency	Air conduction HL range
125 Hz	-10 to +70 dB _{HL}
250 Hz	-10 to +90 dB _{HL}
500 Hz	-10 to +110 dB _{HL}
750 Hz	-10 to +110 dB _{HL}
1000 Hz	-10 to +110 dB _{HL}
1500 Hz	-10 to +110 dB _{HL}
2000 Hz	-10 to +110 dB _{HL}
3000 Hz	-10 to +110 dB _{HL}
4000 Hz	-10 to +110 dB _{HL}
6000 Hz	-10 to +110 dB _{HL}
8000 Hz	-10 to +90 dB _{HL}

Attenuator Linearity: $\pm .5$ dB per 5 dB step, ± 3 dB overall

Distortion: .5% typical, 2% maximum

Sound pressure level calibration accuracy: ± 3 dB

Pulsed stimulus: 2.5 pulses/second, 50% duty cycle

Rise/Fall time: 35 msec. typical

Freq. mod. rate: $\pm 5\%$ triangle wave modulation at 5 Hz modulating rate

Dimensions: 12.5" W x 6.25" H x 15.5" D
32cm W x 16cm H x 40cm D

Weight: 16.5 lb/7.5 kg

Case: Structural foam

Voltage requirements: 117/234 volts AC, switchable



Operating Instructions MA 42

Narrow band noise and bone specifications:

Frequency	Narrow band HL range	Bone conduction HL range
125 Hz	-10 to +60 dB _{HL}	-----
250 Hz	-10 to +80 dB _{HL}	-10 to +45 dB _{HL}
500 Hz	-10 to +100 dB _{HL}	-10 to +60 dB _{HL}
750 Hz	-10 to +100 dB _{HL}	-10 to +70 dB _{HL}
1000 Hz	-10 to +100 dB _{HL}	-10 to +70 dB _{HL}
1500 Hz	-10 to +100 dB _{HL}	-10 to +70 dB _{HL}
2000 Hz	-10 to +100 dB _{HL}	-10 to +70 dB _{HL}
3000 Hz	-10 to +100 dB _{HL}	-10 to +70 dB _{HL}
4000 Hz	-10 to +100 dB _{HL}	-10 to +60 dB _{HL}
6000 Hz	-10 to +100 dB _{HL}	-10 to +50 dB _{HL}
8000 Hz	-10 to +80 dB _{HL}	-----

Rolloff is 12 dB per octave minimum; narrow band calibration is for effective masking.

**Masking level
attenuation:**

Variable intensity with a 5 dB step detent

**Speech air conduction
calibration:**

0 dB_{HL} for a 0 VU signal corresponds to a 19.5 dB SPL

**Speech air conduction
HL range:**

-10 to +100 dB_{HL}, 5 dB steps

Speech input selector:

Selects microphone, CD or tape input

Speech gain adjustment:

Gain control adjusts 40 dB range differences in speech signal level

Speech level indicator:

LED meter with characteristics as defined by ANSI S3.6

Microphone type:

Electret condenser

Tape input:

Sensitivity: 50 mV RMS 0 VU
Frequency response: ± 3 dB, 200 to 4000 Hz
Distortion: 2% THD

Speech noise range:

-10 dB to 100 dB_{HL}

Inputs

CD/tape, live speech microphone, patient microphone and patient response switch

Outputs:

Air, bone, insert phone, free field, and monitor



Operating Instructions MA 42

Master hearing aid:

SPL/Gain control:	15-65 dB gain in 5 dB increments
Calibration accuracy:	± 3 dB SPL
Input calibration level:	0 VU corresponds to 60 dB SPL
Slopes:	Flat, 6, 12 and 18 dB/octave low cut filters

Calibrated to ANSI S3.6 1996.



Operating Instructions MA 42

2.0 INTRODUCTION

2.1 Instrument Description

The MA 42 is a portable two-channel audiometer with master hearing aid, offering pure tone speech and free field audiometric testing. The master hearing aid feature is a tool whereby the operator may simulate several common frequency responses. While adjusting the dB level in each ear, the operator can grossly simulate the sound characteristics of some hearing aids so that patients can benefit from actually experiencing the difference a hearing aid can make in their hearing.

It performs tests using TDH 39 headphones, a B-71 bone conduction receiver, optional insert phones or optional loudspeakers. Built-in test signals include pure tone, pulse tone, warble tone, narrow band and broad band noise. Inputs include ports for live speech and CD/tape speech test material; outputs have separate jacks for TDH 39s, optional insert phones, optional free field speakers, and bone conduction.

The MA 42 offers air conduction frequencies from 125 Hz to 8 kHz, with intensity levels from -10 dB_{HL} to 110 dB_{HL}. Bone conduction test frequencies are 250 Hz to 6 kHz with intensity levels of -10 dB_{HL} to 70 dB_{HL}. Sound field measurements are possible using the built-in amplifier and optional speakers.

The MA 42 has a built-in RS 232 interface. Calibration is performed via the front panel and thus simplifies annual service calibrations.



Operating Instructions MA 42

3.0 UNPACKING AND INSPECTION

3.1 External Inspection

Your MA 42 was carefully inspected and packed for shipping. However, it is good practice to thoroughly inspect the outside of the shipping container for signs of damage. If any damage is noted, please notify the carrier immediately.

3.2 Unpacking

Remove the upper layer of packing material from the top of the instrument. Carefully lift the instrument from the shipping carton and remove the plastic bag. Inspect the case for sign of any damage. Notify the carrier immediately if any signs of mechanical or physical damage are noted. This will ensure that a proper claim is made. Save all packing material so that the claim adjuster can inspect it as well. When the adjuster has completed the inspection, notify the Maico Special Instrument Distributor you purchased this unit from.

Save all the original packing material and the shipping carton so the instrument can be properly packaged if it needs to be returned for service or calibration.

3.3 Accessories Supplied

Standard accessories are packaged and shipped inside the MA 42 storage compartment. Open the compartment by unsnapping the side latches and folding the cover up and back. Please check that all accessories listed below are received in good condition. If any accessories are missing or damaged, notify your Maico Special Instrument Distributor immediately.

Standard Accessories	Part Number
TDH 39 Headset	4687
B-71 Bone Conductor	1034-105
B-71 Bone Cord	2068
B-71 Bone Headband	1037-37
Audiogram pad	1162-417
Operator's Manual	1162-9811
Monitor/Mic Headset	5520
Patient Response switch	2169
Noah Audiometer Module Diskette	1154-2026
Optional Accessories:	
Talk-back microphone	6619
Patch cords	1025-352
Audiocup headset	4695
Insert phones	4790
Free field kit	5525



Operating Instructions MA 42

4.0 FRONT AND REAR PANEL CONTROLS AND DESCRIPTIONS

4.1 Front Panel Controls

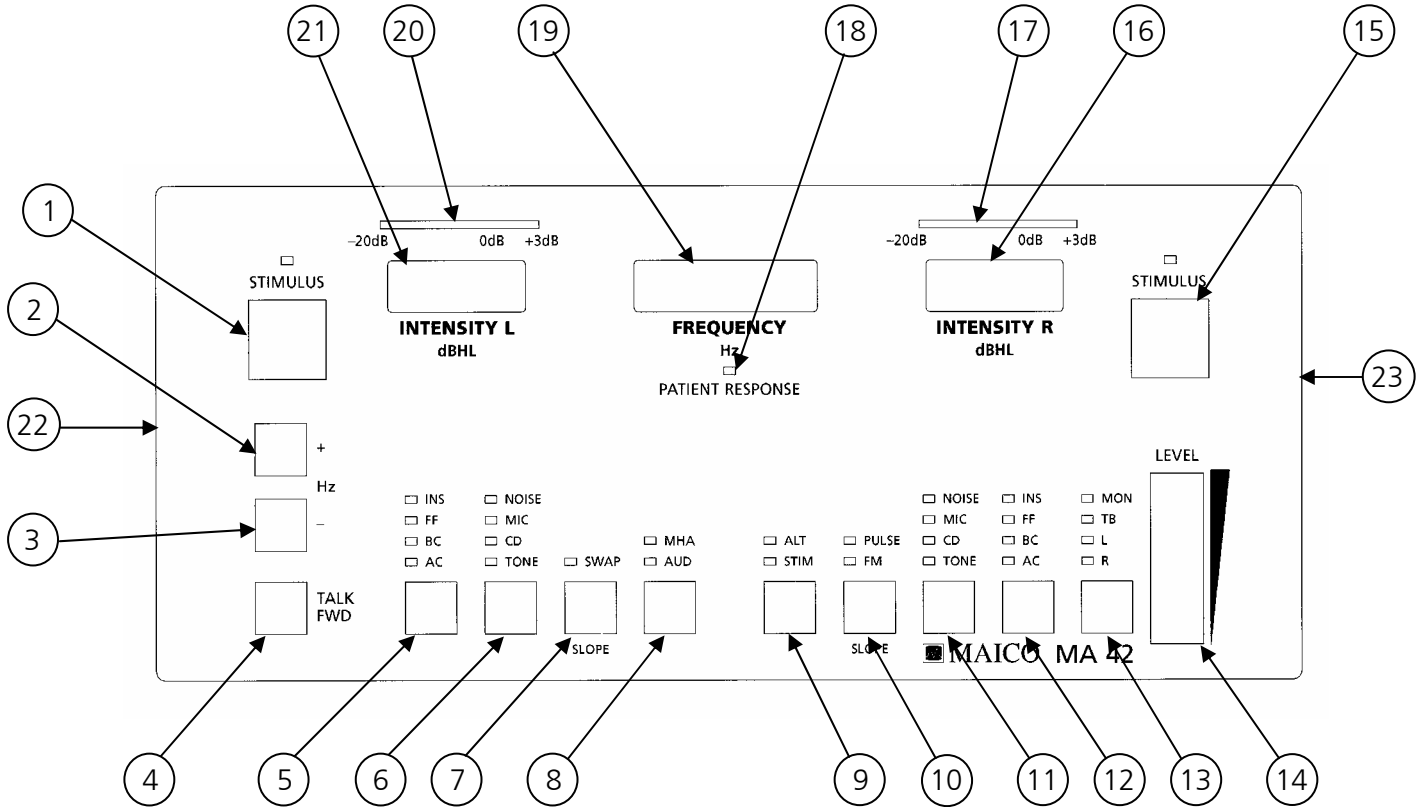

Figure 1

1. STIMULUS. Left stimulus present/interrupt switch. Stimulus is present when the LED is lit.
2. + HZ. Frequency select increase.
3. – HZ. Frequency select decrease.
4. TALK FWD. Talk forward enable. Press and hold to talk to the test subject via the monitor headset microphone or optional speech microphone; adjust the test subject's headphone level via either INTENSITY CONTROL DIAL. (See 22 and 23)
5. LEFT OUTPUT SELECT. Press and release to cycle through the available transducers. LED of selected transducer will light.

INS	Insert Phones
FF	Free Field
BC	Bone Conduction
AC	Air Conduction



Operating Instructions MA 42

6. LEFT SIGNAL SELECT. Press and release to cycle through the available signals. LED of selected signal will light.

NOISE	Masking
MIC	Microphone
CD	Compact Disk/Tape Player
TONE	Pure Tone

7. SWAP/SLOPE. When in audiometer mode (AUD, See 8), press and release to swap selected test ear between left and right. LED will light when SWAP is selected. When in master hearing aid mode (MHA, See 8), press and release to cycle through standard hearing aid slopes for the left ear. Selected slope will be displayed in left side of the FREQUENCY window.

F	Flat
6	6 dB/octave
12	12 dB/octave
18	18 dB/octave

8. MHA/AUD. Press and release to switch between MHA (master hearing aid) and AUD (audiometer) modes. When in MHA mode, the SLOPE functions of Keys 7 and 10 are enabled.
9. ALT/STIM. When in TONE mode on both channels (See 6 and 11) and PULSE mode (See 10), press to enable one of these options:

STIM LED on	Changes function of STIMULUS key from "present" to "interrupt", i.e., stimulus always on unless STIMULUS key is pressed.
ALT LED on	Select PULSE (See 10), select ALT, then press either STIMULUS key to present pulsed stimulus alternately between the left and right ears. Used in ABLB test.
Both ALT and STIM LEDs on	Presents alternating pulsed stimulus to left and right ears and changes function of STIMULUS key from "present" to "interrupt", i.e., stimulus always on unless STIMULUS key is pressed. Used in ABLB test.
Both ALT and STIM LEDs off	Both functions disabled.



Operating Instructions MA 42

10. PULSE/FM/SLOPE. When in audiometer mode (AUD, See 8), PULSE and FM selections are enabled.

PULSE LED on	Pure tone stimulus will be pulsed.
FM LED on	Pure tone stimulus will warble.
Both PULSE and FM LEDs on	Pure tone will pulse and warble.
Both LEDs off	Pure tone stimulus only.

When in master hearing aid mode (MHA, See 8), press and release to cycle through standard hearing aid slopes for the right ear. Selected slope will be displayed in the right side of the frequency window.

F	Flat
6	6 dB/octave
12	12 dB/octave
18	18 dB/octave

11. RIGHT SIGNAL SELECT. Press and release to cycle through the available signals. LED of selected signal will light.

NOISE	Masking
MIC	Microphone
CD	Compact Disk/Tape Player
TONE	Pure Tone

12. RIGHT OUTPUT SELECT. Press and release to cycle through the available transducers. LED of selected transducer will light.

INS	Insert Phones
FF	Free Field
BC	Bone Conduction
AC	Air Conduction



Operating Instructions MA 42

13. MON/TB/L/R. Used with LEVEL adjust (See 14) to calibrate speech sound levels and to adjust monitor headset listening levels.

MON	Adjusts tone and CD/Tape Player sound levels in the monitor earphone. Use the LEVEL control to adjust the sound to your comfort level.
TB	Adjusts the talk-back microphone sound level in the monitor earphone. Use the LEVEL control to adjust the sound to your comfort level.
L	Calibrates speech sound level for the left ear. Use either the calibrating tone on the CD/Tape Player or speak into the microphone while adjusting the LEVEL control until the sound level peaks just below the red.
R	Calibrates speech sound level for the right ear. Use either the calibrating tone on the CD/Tape Player or speak into the microphone while adjusting the LEVEL control until the sound level peaks just below the red.

14. LEVEL. Used with MON/TB/L/R (See 13) to calibrate speech sound levels and to adjust monitor headset listening levels.
15. STIMULUS. Right stimulus present/interrupt switch. Stimulus is present when the LED is lit.
16. INTENSITY R. Displays right channel intensity.
17. VU. Right channel VU meter.
18. PATIENT RESPONSE. LED lights when test subject presses patient response switch.
19. FREQUENCY. Displays frequency in AUD (audiometer) mode, frequency slope in MHA (master hearing aid) mode.
20. VU. Left channel VU meter.
21. INTENSITY L. Displays left channel intensity.
22. INTENSITY CONTROL DIAL. Adjusts left channel intensity.
23. INTENSITY CONTROL DIAL. Adjusts right channel intensity.



Operating Instructions MA 42

5.0 INSTALLATION AND SETUP

5.1 Headset/Insert Phones

Place the MA 42 on a stable counter or table. Flip open the side latches and fold the lid back. Fold the lid back one more time to reveal the accessories that are packaged within the rear storage compartment. If you haven't already done so, unpack and inspect the accessories.

The TDH 39 headphones are serialized and should match the serial number on the instrument. Check to see that the numbers match, as this will confirm that the headphones and MA 42 were calibrated together. The optional insert phones do not have a serial number, but if they were ordered at the same time as the MA 42 they were calibrated to that particular instrument and should not be used on another without recalibration.

Turn the MA 42 around so that you can view the rear jacks. Insert the RED (right) plug of the TDH 39 headset into the right air conduction earphone jack labeled **R**, under **AC (Air Conduction)**. Insert the BLUE (left) plug into the left **AC** earphone jack labeled **L**.

The insert phones are installed in the same manner. Insert the RED (right) plug of the insert phone cord into the insert phone jack labeled **R**, under **INS (INSert phones)**. The BLUE (left) plug is inserted into the jack labeled **L**.

5.2 Bone Conduction Transducer

Insert the bone conduction plug into the port labeled **BC (Bone Conduction)**.

5.3 Microphone

Plug MICROPHONE into the port marked **MIC** and MONITOR into the port marked **MONITOR**.

5.4 Monitor

Plug monitor earphone into the port marked **MONITOR**.

5.5 Patient Response Switch

Locate the **PATIENT RESPONSE** jack on the rear panel and insert the plug end of the switch.



Operating Instructions MA 42

5.6 Sound Room Patch Cords - Optional

When using the MA 42 in a sound room, connect the patch cords from the sound room to the proper right and left earphone/insert phone jacks, patient response jack, bone conduction jack, and talk-back mic.

5.7 Tape/CD Player - Optional

Speech testing may be conducted using live voice via the microphone or recorded speech via a CD or tape player. If you're using a stereo input with a "Y" cable, plug the ends into the **Right** and **Left** ports on the rear panel under the label **CD**. If your input is mono, plug the single cord into the **Right** port under the **CD** label. The signal will automatically be sent to both the right and left channels.

The MA 42 comes with a hinged bracket for an optional CD or tape player. For proper fit the maximum front-to-back dimension of the player should be less than 6 inches. Four pairs of 1-inch square hook and loop tape are provided to attach the player to the bracket.

Remove the backing from three or four of the pieces and place on appropriate locations on the bracket. Make sure the locations you chose do not obstruct the battery access cover of the player. Before removing the other backing determine the proper positioning of the player. The player must sit far enough back on the bracket to allow the player and bracket to swing up for access to the accessory compartment, but not so far back as to hit the rear of the compartment. Once the proper location has been determined remove the backing from the tape and press the player into position on the bracket.

5.8 Speakers - Optional

Free field speakers use the **Right** and **Left** ports under **FF**.



Operating Instructions MA 42

6.0 VOLTAGE AND POWER REQUIREMENTS

The input power rating for this family of audiometers is 117/234 volts AC, 50/60 Hz, 25 W. This product is equipped with a universal power entry module to change the power/mains input voltage from 115 VAC to 230 VAC.

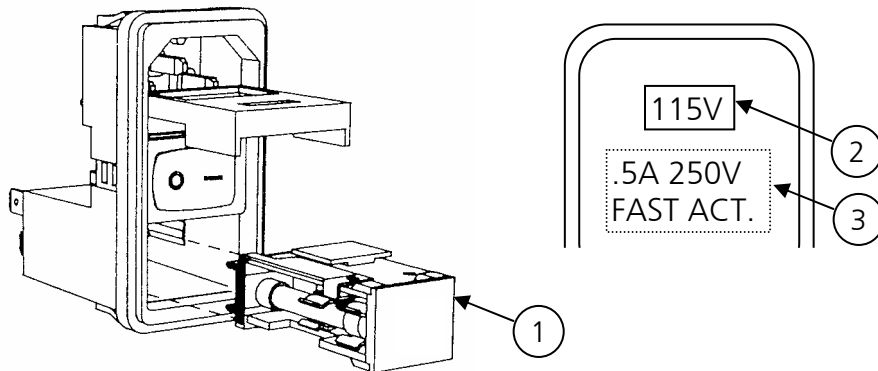

Figure 3. Power entry module (115v shown)

To change the power/mains input voltage for 230 volt operation:

1. Unplug the power/mains cord from the unit.
2. Pry open fuse cover and remove fuseholder (1).
3. Replace fuses with provided .25 amp fuses.
4. Reinstall fuseholder with 230V displayed in window (2).
5. Apply .25A label to the closed cover (3).

Insert the cord set into the recessed socket, then into a three-conductor 117 volt electrical outlet (or the appropriate outlet for your country).

WARNING

This Maico instrument has been designed to meet the most exacting electrical safety requirements for patient care equipment.

The hospital grade, 117 volt alternating current, three-prong plug (or the appropriate plug for your country) should be inserted into a mating three-prong hospital grade receptacle that is properly grounded. This will ensure reliable and safe operation of this precision instrument. Injury to personnel or damage to equipment can result when a three-prong to two-prong adapter is connected between the power plug and an AC outlet or extension cord. If you have any questions, check with your Maico Special Instrument Distributor.



Operating Instructions MA 42

7.0 OPERATION - PURE TONE AUDIOMETRY

7.1 Air Conduction Testing

Air conduction testing is used to measure the patient's hearing threshold levels. The test is usually started on the ear with better hearing.

1. Turn the MA 42 on and let it warm up for 10 minutes before using. Upon power-up the initial setting will be in audiometric testing mode, left ear on air conduction, 1 kHz, 30 dB intensity, right ear on noise, 0 dB.
2. Seat the patient so that he/she is facing away from the instrument at a 90° angle and cannot see what the operator is doing. Give a brief description of what the patient can expect to hear. Using a consistent explanation will help provide more reliable results. Instructions may be expressed as follows: "I am going to place these headphones on your ears. You will hear a tone or beeping sound, which may be loud or soft. Whenever you hear, or think you hear one of these tones, raise your hand. Lower it when you no longer hear the tone. Listen carefully because some tones are very soft."
3. Eliminate any obstructions that could interfere with placement of the earphone cushion on the ear (i.e. hair, earring, eyeglasses, hearing aids, etc.). Adjust the headband so that the earphone cushions are centered over the ears (RED on the right ear, BLUE on the left) and the receivers line up with the ear canals. The headband should rest firmly over the center of the head and place firm pressure on both ears.
4. Set the OUTPUT SELECT to AC and SIGNAL SELECT to TONE. Choose PULSE and/or FM if you wish. Set the INTENSITY and FREQUENCY to the desired level.
5. Press left STIMULUS to present the test tone. The STIM LED should light. If the patient hears the tone he/she will raise their hand or press the patient response switch, indicated by the patient response LED.

The most commonly used hearing threshold procedure is called a modified Hughson-Westlake procedure.

1. Start at 1000 Hz with a level of 0 dB and present a signal for at least 1 second. If no response, increase in 10 dB steps until the patient responds.
2. Increase another 10 dB for a confirmation and orientation. If the patient responds again, decrease the presentations in 10 dB steps until the patient no longer responds.
3. Increase in 5 dB steps until the patient responds. Once the patient responds, descend 10 dB until there is no response. Increase again in 5 dB steps.
4. Repeat until you have 2 out of 3 ascending responses at the same level. Change the frequency and repeat above procedure until you have thresholds for the number of frequencies that you wish to test.

The hearing threshold is defined as the lowest hearing level at which the patient responds to *two out of three ascending stimuli at the same level*.



Operating Instructions MA 42

7.2 Bone Conduction Testing

Bone conduction is the transmission of sound waves through the skull directly to the inner ear. This test conveys useful information about the function of the inner ear and whether there is neural hearing loss. Threshold differences between air conduction and bone conduction are a good indicator of middle ear disease or external ear canal obstruction.

1. Place the bone conduction receiver so that the flat, circular side of the transducer is seated on the mastoid, right on the ledge of the cranial bone behind the auricle. The other side of the headband is placed in front of the opposite ear.
2. Set the OUTPUT SELECT to BC (**B**one **C**onduction) and the SIGNAL SELECT to TONE. Perform the test in the same manner as for air conduction testing (see section 6.1). Record all measurements and results.

7.3 Masking

To ensure that the patient does not experience crossover (sound transmitted through bone conduction over to the opposite ear) you must mask the opposite ear. Masking is performed with a noise signal in the headphone. A narrow band noise is used in pure tone audiometry. The noise automatically changes its center frequency following the frequency of the test tone.

1. Set the OUTPUT SELECT for the ear to be masked to AC and the SIGNAL SELECT to NOISE. Adjust the INTENSITY level to the required masking level.
2. The masking noise is continuously presented for effective masking. You may turn off and on the masking signal by pressing the right STIMULUS key.
3. To mask while performing bone conduction tests, place the headphone on the non-test ear so that the receiver is directly in line with the ear canal. Adjusting the headband, place the other headphone so that it sits directly on the cheekbone.
4. Adjust the masking intensity level whenever you change the test signal level.

7.4 Stenger Test

The Stenger Test is a malingering test in cases of alleged hearing losses or unilateral deafness. It is based on the premise that when two tones of the same frequency are presented simultaneously into both ears, only the louder tone will be perceived. The patient with a feigned hearing loss will not be able to hear the quiet tone, but will also not admit being able to hear the loud tone.

1. Select the desired frequency and adjust the intensity levels with the level control dials. Present the tone with the STIMULUS keys.
2. A common procedure is to present the desired frequency into the better ear at a level of 10 dB above the threshold. At the same time present the signal into the ear with the possible feigned loss at a level 10 dB below the admitted threshold. If the loss in the ear is real, the patient will be unaware of the signal in that ear and will respond only to the tone in the good ear. If the patient does not respond at all, it is likely the admitted threshold is incorrect and you have a "positive" Stenger.



Operating Instructions MA 42

8.0 OPERATION - SPEECH AUDIOMETRY

8.1 Calibrating CD or Tape Speech Test Material

The MA 42 must be calibrated to the particular speech test material in use to ensure valid test levels. *Every time you change the CD or tape you must calibrate the instrument.*

1. Connect the "Y" stereo cable of your tape or CD to the **Left** and **Right** ports under the **CD** label on the rear panel. If you are using a mono input with only one cable, plug it into the **Right** port. The MA 42 will automatically feed the signal to both channels.
2. Select CD on the SIGNAL SELECT keys #6 and #11(see page 7), then select the right channel (R) on key #13. Start the calibration tone on the tape/CD and turn the LEVEL wheel until the signal peaks just below the red LEDs on the VU meter.
3. Repeat for the left channel.

8.2 Calibrating the Microphone for Live Speech Testing

1. Connect the monitor headset cables to **MIC** and **MONITOR** on the rear panel.
2. Select MIC on the SIGNAL SELECT keys #6 and #11(see page 7), then select the right channel (R) on key #13. Speak test words while turning the LEVEL wheel until the signal peaks just below the red LEDs on VU meter.
3. Repeat for the left channel.

8.3 Talk-Back Microphone and Monitor Headset

1. Connect the talk-back mic to the port labeled **TB**, and the monitor earphone to the port labeled **MONITOR**.
2. Select TB, key #13 (see page 7), and adjust the sound level to your comfort using the LEVEL wheel. Select MON, key #13, and adjust the sound level to your comfort using the LEVEL wheel.

8.4 Monitor Speaker

If you do not wish to use the monitor earphone, you may listen to the tape/CD input and the patient talk-back mic via the MONITOR SPEAKER. To do this, simply do not connect the monitor, select TB (key #13 as in 8.3), then adjust the volume to your comfort with the LEVEL wheel. Repeat for MON.



Operating Instructions MA 42

8.5 Speech Testing

The SRT (Speech Reception Threshold) is defined as the lowest intensity level at which the patient can correctly repeat the speech stimuli (i.e. baseball, hot dog, ice cream) 50% of the time. A modified version of this procedure utilizes a picture board where the patient correctly points to the picture that corresponds to the speech stimulus.

1. Explain to the patient that he/she should repeat each word they hear.
2. Eliminate any obstructions that could interfere with placement of the earphone cushion on the ear (i.e. hair, earring, eyeglasses, hearing aids, etc.). Adjust the headband so that the earphone cushions are centered over the ears (red on the right ear and blue on the left) and the receivers line up with the ear canals. The headband should rest firmly over the center of the head and place firm pressure on both ears.
3. Set the OUTPUT SELECTS to AC and the SIGNAL SELECTS to CD or MIC, depending on your input.
4. You may use the monitor phone or the monitor speaker to hear the test words and the patient's response.
5. Set the start level.
6. Perform the test words.

You may perform the speech test with free field speakers or bone conduction by selecting the appropriate OUTPUT SELECT.

Masking may be used with speech testing by selecting NOISE masking on the opposite channel. The MA 42 will automatically produce speech weighted noise.

8.6 MCL (Most Comfortable Level) Procedure

The MCL test determines the level at which a patient finds listening to speech most comfortable. This procedure is normally done after you have obtained a Speech Reception Threshold and is important for selecting appropriate aided amplification.

1. Begin by presenting speech levels (either live voice or recorded) at a 30 - 40dB_{HL} level above the patient's SRT.
2. Conduct a bracketing procedure similar to pure tone threshold testing and have the patient indicate at what level the speech is most comfortable.
3. Record the level.

8.7 UCL (Uncomfortable Loudness Level) Procedure

The UCL is another important test used to determine the acoustic dynamics of aided amplification. The test procedure is very similar to the MCL, except that the level you are looking for is that which the patient feels would be unbearable for any length of time. Begin this test with an ascending procedure starting with the patient's recorded MCL.



Operating Instructions MA 42

9.0 MASTER HEARING AID

After you have completed the MCL test you may wish to demonstrate to the patient the difference a hearing aid can make. Use the MA 42 master hearing aid to adjust various frequency slopes for speech:

1. Set the intensity level to the patient's MCL.
2. Select the most appropriate frequency response for the individual's hearing loss.
3. Use either live voice or recorded speech material to demonstrate how speech could sound with amplification.

In MHA mode the displays show hearing aid gain in dB. The SPL level presented to the patient is 60 dB SPL @0 VU, plus the displayed gain.

Note: The MCL, UCL and MHA functions can be performed using monaural or binaural presentations.



Operating Instructions MA 42

10.0 NOAH INSTALLATION INSTRUCTIONS

This section assumes that you have previously installed your own NOAH3 software program. The following instructions will help you use your Maico equipment with your PC after it has been inter-connected with a standard 9 pin RS232 cable.

10.1 Maico Audiogram Module Installation

The Maico Audiogram Module provides some enhanced data transfer functions that are not available on the standard NOAH audiogram format. For example, you will be able to transfer SRTs, speech MCL and UCL information under earphones or in the free field test situation.

1. Make sure NOAH is not running.
2. Insert the Audiogram Module CD.
3. Run the setup.exe program on the CD.
4. Follow the installation instructions on the screen.

10.2 Activating the Audi-Link Driver

1. Start NOAH.
2. Select a client.
3. Click on "Open Module Selection."
4. Select "Measurement."
5. Choose the "Maico Aud 3.0" option.
6. Select "Online Mode" to start communications with the audiometer.

10.3 Transferring SRT, MCL and UCL Information on the MA 42

1. Select either microphone or CD input on the MA 42.
2. Perform SRT test.
3. Press the corresponding Stimulus key for the ear tested and the data will appear in the speech fields.
4. MCL function – press the + Hz key and MCL will appear in the frequency screen. The symbol does not look like an M, but instead an upside down U. This is because of the limitations of the LED segment display. Press the stimulus key for the desired test ear and the data will appear in the appropriate MCL box.
5. For UCL, press the – Hz key and the UCL will appear in the frequency screen. To transfer your data simply press the stimulus key for the ear tested and the data will appear in the appropriate UCL box.



Operating Instructions MA 42

11.0 MAINTENANCE

11.1 Preventive Maintenance

To maximize the service life of your audiometer and accessory equipment, we suggest the following:

1. Turn off the instrument overnight.
2. Wipe the headset cords, ear cushions and casing occasionally with a cloth dampened (not dripping wet) with warm water. Dry with a soft cloth.
3. Leave the accessories such as the headset, bone vibrator and monitor phone permanently connected to the audiometer to minimize strain on the connections. It is not necessary to disconnect accessories not in use while performing other tests. Should it be necessary to disconnect cords, always grasp the barrel of the plug — never pull the cords. Never drop or snap the headphones together. Mechanical shock may change the earphone's electrical and operational characteristics and require recalibration of the MA 42.
4. Close the audiometer cover at the end of each day to minimize dust collection.
5. Avoid sharply bending or twisting any of the cords. Although they are designed to be highly flexible, rough treatment may cause damage. Broken or defective cords can cause crackling noise and intermittent or weak operation in the headset, microphone and bone vibrator. Headset, bone vibrator and microphone cords may be replaced without recalibrating the audiometer.

11.2 Cleaning the MA 42

First, disconnect the power cord **before** cleaning. Clean the instrument, headphones, bone conduction receiver, loudspeakers and other accessories with a soft cloth dampened with a little warm, soapy water. Do not use alcohol to clean.

The ear cushions of the headphones can be detached for cleaning. To remove, gently pull the cushion away from the headphone. To re-assemble, press it back onto the headphone. Make sure that the sound outlet hole sits exactly in the middle of the earphone.



Operating Instructions MA 42

11.3 Calibration

The optimum length of time between calibrations for audiometers varies, depending upon the treatment given the instrument and the headphones. It is recommended that the instrument have a laboratory calibration at least once every year. Since rough handling, such as dropping the headphones, can easily cause calibration errors it is advisable to establish a biological calibration check as soon as you receive the instrument.

Should you feel at a later date that the audiometer's calibration might be in error, perform a biological check on a known ear. If all re-tests show major changes, calibration is probably in error.

All repair and calibration should be done at an authorized Maico Special Instruments Distributor service center. This assures the use of quality materials by trained and experienced technicians using the proper, accurate equipment.

Maico Special Instruments Distributors are located in major cities throughout the world. To minimize costs and time delays, contact the Distributor that you purchased the instrument from. If you don't know who that is, or need to find the Distributor closest to you, contact the factory at:

Maico Diagnostics
7625 Golden Triangle Drive
Eden Prairie, MN 55344
Toll free 888-941-4201
Phone 952-941-4200
Fax 952-903-4200

Customers outside of North America and South America may contact:

Maico Diagnostic GmbH
Salzufer 13/14
10587 Berlin, Germany
Phone ++030 70 71 46 50
Fax ++030 70 71 46 99



Operating Instructions MA 42

11.4 Shipping Instructions for Calibration and Repair

In the event it becomes necessary to return the instrument for calibration or repair, please follow these instructions:

1. Place the instrument in the original shipping carton, using the packaging provided. Be sure to include all accessories, as they are required for proper calibration.
2. Enclose an explanatory letter describing the service you require, carefully detailing any operational problems. Be sure to include your name, phone number, the serial number and your full return address for return shipping.
3. Ship, prepaid, to your Maico Special Instrument service center.

NOTE: Warranty service is provided by your authorized Maico Special Instruments Distributor.

**DO NOT ATTEMPT TO REMOVE THE INSTRUMENT CASE YOURSELF.
THIS SHOULD BE DONE ONLY BY AN AUTHORIZED MAICO SERVICE
TECHNICIAN.**

