



# Operating Instructions

## Quik Tym<sup>®</sup>1 (MI 20), Quik Tym<sup>®</sup>2 (MI 21)





# Operating Instructions

## Quik Tymp<sup>®</sup> 1 (MI 20), Quik Tymp<sup>®</sup> 2 (MI 21)

### TABLE OF CONTENTS

<b>WARRANTY</b> .....	<b>1</b>
<b>1.0 SPECIFICATIONS</b> .....	<b>2</b>
<b>2.0 INTRODUCTION</b> .....	<b>4</b>
2.1 UNDERSTANDING TYMPANOMETRY AND AUDIOMETRY EXAMS .....	4
<b>3.0 SETTING UP AND INSTALLATION</b> .....	<b>5</b>
3.1 UNPACKING .....	5
3.2 WHERE TO SET UP .....	5
3.3 HOW TO SET UP .....	5
<b>4.0 KEYS</b> .....	<b>6</b>
4.1 KEY PAD FOR THE QUIK TYMP 1 TYMPANOMETER .....	6
4.2 KEY PAD FOR THE QUIK TYMP 2 TYMPANOMETER/AUDIOMETER .....	7
<b>5.0 SET UP MODE</b> .....	<b>8</b>
5.1 USER MENU AND SET UP OPTIONS .....	8
5.2 USER SET UP .....	8
<b>6.0 GETTING STARTED</b> .....	<b>9</b>
6.1 PERFORMING AN AUDIOMETER TEST .....	9
6.2 ACCESSING THE AUDIOMETER OPTION THROUGH THE KEY PAD .....	9
6.3 PATIENT RESPONSE USING THE OPTIONAL PATIENT RESPONSE KEY .....	10
6.4 PROGRAMMING THE SET UP SCREEN FOR THE AUDIOMETER .....	11
6.5 PREPARING A CHILD FOR A TYMPANOMETRY EXAM .....	11
6.6 PERFORMING THE TYMPANOMETRY TEST .....	12
6.7 GRAPHICS AND SCREENS .....	12
<b>7.0 THE TYMPANOGRAM</b> .....	<b>14</b>
7.1 NORMAL TYMPANOGRAMS .....	14
7.2 ABNORMAL TYMPANOGRAMS .....	14
<b>8.0 FREQUENTLY ASKED QUESTIONS</b> .....	<b>16</b>
8.1 HOW DO I LOAD THE PAPER ROLL? .....	16
8.2 REMOVING OLD PAPER ROLL .....	17
<b>9.0 ROUTINE CARE</b> .....	<b>18</b>
9.1 CARE OF THE UNIT .....	18
9.2 CARE OF THE TYMPANOMETER PROBE .....	18
9.3 CARE OF THE EAR TIPS .....	18
9.4 CARE OF THE AUDIOMETER HEADPHONES (QUIK TYMP 2) .....	18
9.5 CALIBRATION OF THE INSTRUMENT .....	19
9.6 SHIPPING INSTRUCTIONS FOR RE-CALIBRATION AND REPAIR .....	20



# Operating Instructions

## Quik Tymp<sup>®</sup> 1 (MI 20), Quik Tymp<sup>®</sup> 2 (MI 21)

---

### WARRANTY

This warranty is extended to the original purchaser of the Quik Tymp 1 (MI 20), or Quik Tymp 2 (MI 21) by Maico, through the authorized Special Instrument Distributor from whom it was purchased. This warranty covers defects in material and workmanship for a period of one year from date of delivery.

Should the Maico Quik Tymp 1 or Quik Tymp 2 require service due to a defect in material or workmanship, Maico, at its option, will repair or replace the instrument at no charge except for transportation to and from the point of service. It is the purchaser's responsibility to return the Quik Tymp 1 or Quik Tymp 2 to the Maico Special Instrument Distributor from whom it was purchased or directly to Maico after receiving a return authorization.

This warranty does not cover breakage or failure caused by tampering, misuse, carelessness, accident or modification. The warranty is void if the instrument is serviced by other than an authorized Maico Special Instrument Service Center.

### NOTE:

Specifications in this manual are in effect at the time of printing. Maico reserves the right to modify or change specifications or design at any time without notice or incurring obligation.

### WARNING

The Maico Quik Tymp 1 (MI 20) and Quik Tymp 2 (MI 21) are designed to be used only with the supplied 18 VAC adapter. Injury to personnel or damage to equipment can result if this adapter is modified or replaced with an incorrect adapter.

**NOTE:** Warranty service is provided by your authorized Maico Special Instruments Distributor.

**DO NOT ATTEMPT TO REMOVE THE INSTRUMENT CASE YOURSELF.  
THIS SHOULD BE DONE ONLY BY AN AUTHORIZED MAICO SERVICE  
TECHNICIAN.**



# Operating Instructions

## Quik Tym<sup>®</sup>1 (MI 20), Quik Tym<sup>®</sup>2 (MI 21)

---

### 1.0 SPECIFICATIONS

#### **TYMPANOMETRY MODE**

Probe frequency:	226 Hz $\pm$ 3%, typical
Probe intensity:	85 dB SPL $\pm$ 2.0 dB measured into a 2cc cavity, AGC controlled
Probe Distortion:	Less Than 5%
Pressure range:	+200 to -400 daPa, Sweep stops -200 daPa from the peak
Pressure Accuracy:	$\pm$ 15% or $\pm$ 10 daPa, whichever is greater
Rate of sweep:	400 daPa/sec
Test time:	5 seconds
Ear Canal Volume Range:	0.2 to 6.0 cc
Compliance ranges:	0.2 to 4.5 cc
Compliance Accuracy:	$\pm$ 0.1 cc or 5% whichever is greater over the Compliance Range
Uncompensated Compliance:	5.0 cc
Compensated Range:	0.0 To 1.0 cc, 0.0 To 2.0 cc, 0.0 To 3.0 cc

#### **REFLEX MODE**

Reflex Tone:	1 kHz
Reflex Level:	100 dBHL
Accuracy:	$\pm$ 3%
Total Harmonic Distortions:	<5%
Determination:	Compliance Change $>$ .062 cc
Pressure:	Automatically Returns To Peak Compliance Point

#### **DISPLAY**

Type:	LCD
-------	-----

#### **PRINTER**

Type:	Fujitsu Thermal
-------	-----------------

#### **Probe**

Weight:	4 oz.
Dimensions:	1" X 2 1/2" X 1 1/4"

#### **Mechanical**

Dimensions:	11 3/4" X 8 1/2" X 5 1/2" Envelope
Weight:	5 Lbs.
Voltage:	117v $\pm$ 10%

#### **Environmental**

Operational Temperature:	15 to +40C
Storage Temperature:	0 to +60C
Relative Humidity:	5% To 90%



# Operating Instructions

## Quik Tym<sup>®</sup>1 (MI 20), Quik Tym<sup>®</sup>2 (MI 21)

---

### **AUDIOMETRY (Quik Tym 2 only)**

Frequencies:	250, 500, 1000, 2000, 3000, 4000, 6000, and 8000 Hz
Decibel Range:	0-85 dB in 5 dB steps
Frequency Accuracy:	± 2%
Noise Level:	-10 dBHL or 70 dB Below The Test Tone, Whichever Is Greater
Distortion:	Less Than 3% THD
Level Accuracy:	± 3 dB Of Levels Specified In ANSI S3.6-1996

### **Tone Presentation**

Rise/Fall Time:	35 ± 15 Milliseconds
On/Off Ratio:	Greater Than 70 dB At All Frequencies

### **Output**

Earphones:	TDH-39 With 100 Ohm Coils
Crosstalk:	-70 dB Or Less Than - 5 dB HI Whichever Is Greater



# Operating Instructions

## Quik Tymp<sup>®</sup> 1 (MI 20), Quik Tymp<sup>®</sup> 2 (MI 21)

---

### 2.0 INTRODUCTION

MAICO specifically designed the Quik Tymp 1 and Quik Tymp 2 to meet the unique challenge of performing tympanometry.

#### 2.1 UNDERSTANDING TYMPANOMETRY AND AUDIOMETRY EXAMS

Tympanometry can determine:

- Whether there is fluid behind the eardrum in the middle ear space
- The mobility of the Tympanic membrane
- The presence of negative pressure in the middle ear space
- The presence of a perforation in the Tympanic membrane

Acoustic/Ipsilateral Reflex (with tympanometry exam)

- Tests the stapedial muscle response, indicating normal activity of the ossicular bone chain.

Audiometry can determine:

- Permanent hearing loss
- Temporary hearing loss due to otitis media or other factors
- The return of "normal" hearing levels after treatment

Tympanometry is a test of middle ear function, not a hearing test. It is possible to be completely deaf and still have normal tympanograms. Tympanometry is painless and takes seconds to complete. During the test a soft "hum" tone is presented at 85 dB SPL through the probe and air is released, changing the air pressure in the outer ear canal. The tympanometer™ provides an automatic recording of the air pressure in the external canal and the change in mobility of the Tympanic membrane (eardrum).

Your unit has been equipped with an optional acoustic reflex tone. When programmed to be turned on, at the end of the tympanometry test, a tone at 100 dB HL at 1000 Hz is provided to test the acoustic reflex (ipsilaterally).

The graph on the display and on the printout (tympanogram) is a graphic representation of the mobility of the eardrum. For example, a patient with otitis media has a build up of fluid behind the eardrum causing the eardrum to be stiff. When a tympanogram is done on this patient, an abnormal or flat graph line or "peak" will be shown indicating a lack of mobility due to the pressure of fluid behind the eardrum. This is illustrated in graphs A<sub>s</sub>, B and C on the front of your unit.

Tympanometry gives the medical provider precise information about the middle ear and allows the caregiver to plan the best treatment for the patient. A thorough caregiver will use both tympanometry and audiometry to ensure the patient has normal hearing and middle ear function before referral to a specialist.

Audiometry testing determines how well the patient can hear. Testing is done using tones that combine different levels of frequency (Hertz-Hz) with different levels of loudness (Decibel-dB).



# Operating Instructions

## Quik Tymper<sup>®</sup> 1 (MI 20), Quik Tymper<sup>®</sup> 2 (MI 21)

### 3.0 SETTING UP

#### 3.1 UNPACKING

The Quik Tymper 1 and Quik Tymper 2 units come in their own box specifically designed to provide the best protection during transportation. Save the box and packing material for your transporting needs. Your unit should contain the following:

- Quik Tymper 1 (MI 20) or Quik Tymper 2 (MI 21)
- Probe
- Power supply module
- Ear tip kit
- 4" thermal paper rolls (2)
- TDH-39 Headphones (for Quik Tymper 2)
- Patient Response Switch
- Warranty card
- User's guide
- Calibration Certificate

If any item is missing, please call your local sales representative or MAICO.

#### 3.2 WHERE TO SET UP

The ideal area for setting up the Quik Tymper 1 or Quik Tymper 2 is in a quiet room furnished with a desk or table. If a separate room is not available, locate a private area where distractions and noise can be minimized.

#### 3.3 HOW TO SET UP

- 1) Plug the connector of the hand held probe firmly into the circular jack, which is located on the back of the unit, on the right side, (you will see a small white plastic connector directly above the jack). Plug the small white plastic air hose into the white connector directly above the probe jack.
- 2) Plug the circular connector of the AC adapter firmly into its circular jack, which is located on the back of the unit on the top left side. Then plug the AC adapter into the wall outlet. Note: Always plug the AC adapter into the unit first.
- 3) If you have purchased the Quik Tymper 2 (MI 21), plug the headphones into the headphone jack on the far right side.
- 4) If you have purchased a response switch to conduct audiometric exams with the Quik Tymper 2 (MI 21), plug the response switch into the lower left-hand jack, just below the power module jack.
- 5) Verify there is paper in the printer, lift up on the side bar of the printer cradle cover:

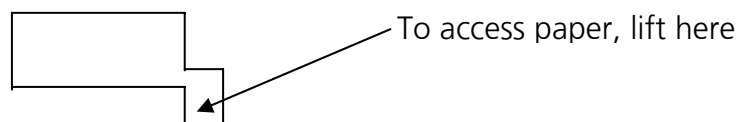

**NOTE:** Your unit is equipped with an internal printer. There are no additional wires to plug in to print an exam. The unit will print tympanograms with ipsilateral reflex result and audiogram on the same sheet.



# Operating Instructions

## Quik Tympanometer® 1 (MI 20), Quik Tympanometer® 2 (MI 21)

---

### 4.0 KEYS

#### 4.1 KEY PAD FOR THE QUIK TYMPANOMETER 1 (MI 20)

Six (6) keys operate the Quik Tympanometer 1 (MI 20). The function of each key is as follows:

- **POWER**

Press this key to “power up” the system. The system will first go through a quick self-test and the screen will illuminate with the “little car” and then the Quik Tympanometer logo. When the logo appears and the unit “beeps” the system is ready to begin testing.

- **NEW**

Press this key before you test each new patient. The “little car” visual distraction will appear on the screen.

**NOTE:** All previous test results will be cleared and erased from memory once the **NEW** key is pressed.

- **SELECT**

Can be used to program and customize the unit by your clinic needs and preferences. Performs two separate functions:

- 1) Press this key when you want to toggle between “little car” graphics and tympanogram. Ideal when using the unit to test children or adults who do not need to be visually distracted to perform the exam.
- 2) Hold down this key for 4 seconds to view the **OPTIONS** screen offered for customization. Please turn to the “User Menu Options” section in this manual, when you wish to review available selections.

- **RETEST**

Press this key when you want to retest an ear.

The “little car” or tympanometer graph will appear on the screen.

**NOTE:** The results from the ear “*just tested*” will be deleted from memory. If you wish to have a partial test shown, this can be changed in the **SELECT** mode. The previous L or R test will be saved if a retest was necessary in only one ear.

- **R/L EAR**

Press this key to switch to the “other” ear.

“L” (left) or “R” (right) will be displayed on the screen and printed on the test results.

This key can be pressed to “toggle” between (left and right) screens to compare test results before printing

- **PRINT**

Press this key to print the results after testing one or both ears.



# Operating Instructions

## Quik Tymp<sup>®</sup>1 (MI 20), Quik Tymp<sup>®</sup>2 (MI 21)

---

### 4.2 KEY PAD FOR THE QUIK TYMP 2 (MI 21)

Twelve (12) keys operate the Quik Tymp 2 (MI 21). You may conduct a test immediately before or after a tympanometry exam, or an audiometry exam alone. You will see all of the above keys in addition to the following:

- **LEVEL ↑**

Press this key to increase decibel level of tone.

Each time this key is pressed, the tones will go up by 5 dB's.

- **STIM**

Administers the tone to the patient.

When the **STIM** key is depressed, a "+" signal will show on the screen. As long as this key is depressed, the tone will be presented.

- **LEVEL ↓**

Press this key to decrease decibel level of tone.

Each time this key is pressed, the tones will go down by 5 dB's.

- **FREQ**

Press this key for the next frequency.

If a patient does not respond to a tone, the operator will press the **FREQ** key, and a question mark (?) will appear in the box. The asterisk (\*) will automatically move and note the next frequency and decibel to be presented.

- **ENTER**

Press this key to enter the FINAL decibel heard at each Frequency.

After establishing the patients threshold (done by the patients response to the tone administered when the **STIM** key is depressed), the operator should depress the **ENTER** key to record the final response/threshold. A # will appear on the screen. The asterisk (\*) will automatically move and note the next frequency and decibel to be presented.

**NOTE:** Patients respond by raising their hand or using an optional patient response key.

- **AUDIO/TYMP/CD**

Will toggle between audiogram and tympanometry exam.

At the end of the audiometer screening, the operator has the option to perform a tympanometry exam or vice versa by depressing this key. A review of all exams can be viewed also by depressing this key.



# Operating Instructions

## Quik Tymp<sup>®</sup> 1 (MI 20), Quik Tymp<sup>®</sup> 2 (MI 21)

---

### 5.0 SET UP MODE

#### 5.1 USER MENU AND SET UP OPTIONS

After the system is “powered up” and the **NEW** key has been pressed, hold down the **SELECT** key for 4 seconds. The following menu of choices will appear on the screen.

#### 5.2 USER SET UP

- **REFLEX:**  
ON/OFF (default: OFF) (Ipsilateral/Acoustic Reflex Test)
- **VISUAL DISTRACTION:**  
ON/OFF (default: ON) (“little car” display graphics)
- **AUTOABORT:**  
ON/OFF (default: ON) (When “ON”, the unit will “automatically” reset the test when the probe seal is broken, saving time. When “OFF” the unit provides the opportunity (when necessary) to obtain “partial” test results.)
- **OFFICE INFORMATION:**  
(Name, Address and Phone Number. If programmed, this information would PRINT on every patient exam.)
- **To select a letter, number, or character from the listing:**
  - Press the **RETEST** key to scroll “up” or the **R/L EAR** key to scroll “down” (through the letters, numbers or characters).
  - Press the **SELECT** key to move forward one space along that line.
  - Press the **NEW** key to move backward one space along that line.
  - Press the **PRINT** key when that line is complete.
  - Press the **SELECT** key to scroll to the next line.
  - Press the **SELECT** key to scroll down the list.
  - Press the **ENTER** key to change an option.
  - Press the **NEW** key when the selections are completed.



# Operating Instructions

## Quik Tymper<sup>®</sup> 1 (MI 20), Quik Tymper<sup>®</sup> 2 (MI 21)

### 6.0 GETTING STARTED

Once the Quik Tymper unit is plugged in and the **POWER** key is depressed, the unit will be “standing by” and “ready” for keypad operation.

#### 6.1 PERFORMING AN AUDIOMETER TEST

The audiometer option of your Quik Tymper 2 (MI 21) can be used for all your pure tone screening and threshold testing requirements. Your Quik Tymper 2 (MI 21) comes with one set of TDH-39 headphones.

With the back of the unit facing you:

- 1) Plug the connector of these headphones firmly into the circular “Headphones” jack located to the right of the probe connector on the backside of the unit.
- 2) If you wish to conduct the test using the response switch as opposed to “raising the hand when a tone is presented”, plug the response switch into the lower left hand jack, just below the power module jack.
- 3) Place the headphones onto the patient. Please note that the TDH-39 headphones have a “right” and a “left” ear cup. As the headband is fitted over the patient’s head, the cup with the red marker should be positioned on the patient’s right ear and the cup with the blue marker should be positioned on the left. The cups should be positioned so that they cover the ears and fit snugly to the patient’s head. Long hair should be moved away from the ears before positioning the headphones.

#### 6.2 ACCESSING THE AUDIOMETER OPTION THROUGH THE KEY PAD

After your unit is powered up, press the **NEW** key and press the bottom right key labeled **TYMP AUDIO CD**. The following screen will then be displayed:

kHz	.25	.5	1	2	3	4	6	8
R dB	25*	25	25	25	25	25	25	25
L dB	25	25	25	25	25	25	25	25

The top row (kHz) indicates the frequencies that each tone will be presented at.

**NOTE:** This row cannot be changed, but can be turned “on” or “off”.

The row on the left (R dB and L dB) indicates the ear that will be receiving the tone.

All center columns and rows (where 25 is shown) indicates the decibel (dB) levels for both ears and is preset at the factory (25 dB). This can be reprogrammed based on your clinic needs. Please refer to the section below under “PROGRAMMING THE SET UP SCREEN.”



# Operating Instructions

## Quik Tympanometer<sup>®</sup> 1 (MI 20), Quik Tympanometer<sup>®</sup> 2 (MI 21)

---

A flashing asterisk (\*) will appear to the right of each decibel value to indicate that a response has not been recorded for the ear being tested by frequency. (For example: in above chart, the asterisk appears next to the 25 dB of the right ear (R dB) at the kilohertz frequency of 250 (.25 kHz).

When administering a tone, press the **STIM** key. The asterisk (\*) will change to a plus sign (+) to indicate that a tone is being presented. If the patient responds to the tone, usually by raising their hand, the operator may depress the **ENTER** key to go to the next frequency or the **LEVEL ↑** or **LEVEL ↓** key to proceed to the next decibel value.

**NOTE:** Each time a decibel level is changed, (by pressing the **LEVEL ↑** or **LEVEL ↓** key), the **STIM** key must be depressed to deliver the tone. Once the desired response is achieved and the operator wishes to move to the next frequency, the **ENTER** key should be pressed to record the response.

### 6.3 PATIENT RESPONSE USING THE PATIENT RESPONSE SWITCH

When using the patient response key, if the patient responds to the tone while the **STIM** key is depressed, the frequency box will turn to black. The operator should then depress the **ENTER** key to go to the next frequency or the **LEVEL ↑** or **LEVEL ↓** key to proceed to the next decibel value.

**NOTE:** Each time a decibel level is changed, (by pressing the **LEVEL ↑** or **LEVEL ↓** key), the **STIM** key must be depressed to deliver the tone. Once the desired response is achieved and the operator wishes to move to the next frequency, the **ENTER** key should be pressed to record the response.

If the patient does not respond to a tone, the operator may press the **FREQ** key to skip that frequency/decibel level. A question mark (?) will appear in the box to indicate non-response. The asterisk (\*) will automatically move on to the next frequency to be presented.

When the screening of the right ear is completed, the asterisk (\*) will automatically move to the left ear (L dB).

During the screening, the operator can increase or decrease the preset decibel levels of each box by pressing the **LEVEL ↑** or **LEVEL ↓** key. When the decibels are increased or decreased to the desired level, the operator should press the **STIM** key to deliver the tone to the patient.

At the end of the audiometer screening, the operator has the option to:

- Print out the audiogram by pressing the **PRINT** key. If tympanometry was performed before the audiogram, these results will print out on the same sheet.
- To review the tympanogram before printing the results. The operator can “toggle” back and forth between the audiogram and the tympanogram by pressing the **TYMP AUDIO CD** key.



# Operating Instructions

## Quik Tymp<sup>®</sup> 1 (MI 20), Quik Tymp<sup>®</sup> 2 (MI 21)

### 6.4 PROGRAMMING THE SET UP SCREEN FOR THE AUDIOMETER

To reprogram the factory preset decibel (dB) levels for each screening, enter the Set up Screen:

After the system is “powered up” press the **NEW** key and then the **TYMP AUDIO CD** key. When the audiometer screen appears, press and hold down the **SELECT** key for 4 seconds. The following screen will appear on the screen:

kHz	.25	.5	1	2	3	4	6	8
Tst:	Yes	yes	yes	yes	yes	yes	yes	yes
dB:	25	25	25	25	25	25	25	25

The selected frequency to be programmed is indicated by the flashing “^” symbol. Pressing the **LEVEL ↑** or **LEVEL ↓** keys will increase or decrease the set decibel (dB) of each frequency. To go to the next frequency, press the **FREQ** key. Toggle the **ENTER** key for each frequency to select Yes (to test) or No (do not test at this frequency).

When the operator has completed the desired programming, press the **NEW** key to return to the audiometer screen. The reprogramming (dB and frequencies: yes/no) will be saved in memory and will continue to appear on the audiometer screen each time the power is turned on unless reprogrammed at a later date.

### 6.5 PREPARING A CHILD FOR A TYMPANOMETRY EXAM

The best way to prepare a child is to pretend that he/she is going to play “a game.” Suggesting that the child is going to “play a game” will assist in reducing the anxiety that may be associated with the test.

Tympanometry can be performed while sitting or standing. The most important consideration is to make the patient as comfortable as possible so he/she can be “still” for just the few seconds necessary to perform the test.

The Quik Tymp 1 and Quik Tymp 2 offer an option of a “little car” visual distraction. When using this option, the child can be told that his/her part in the “game” is to remain as “still” as possible so they can help the car move across the screen, enter the garage and “honk” its horn. (The “horn” is the tone presented to test the ipsilateral reflex. It will only occur if you change the acoustic reflex to “ON” in the set up mode).



# Operating Instructions

## Quik Tym<sup>®</sup>1 (MI 20), Quik Tym<sup>®</sup>2 (MI 21)

### 6.6 PERFORMING THE TYMPANOMETRY TEST

- **INSERTING THE PROBE WITH A CHILD:**  
Place the hand held probe (with proper ear tip) inside the child's ear while gently pulling the earlobe down. Check for excess wax or obstructions. Because children have very small ear canals, this allows the operator to maintain a seal easily.
- **INSERTING THE PROBE WITH AN ADULT:**  
Place the hand held probe (with proper ear tip) inside the patient's ear while gently pulling the top of the ear (the Pinna) up and towards you. Check for excess wax or obstructions.

During the testing, concentrate on holding the probe steady.

- BLINKING RED = Unit is in "stand by"
- GREEN LIGHT = Test is in progress
- SOLID RED (with steady tone) = Probe is blocked
- FLASHING RED (with three beeps) = "broken" probe seal

**NOTE:** The ear tip does not need to go into the ear canal. It should only seal the canal opening. Attempt to point the end of the ear tip into the canal, toward the eardrum. Depending on the patient, a smaller (white or blue) or larger (gray or red) size ear tip may be needed to secure a proper seal.

### 6.7 GRAPHICS AND SCREENS

The Quik Tym 1 and Quik Tym 2 have two options for graphics:

- 1) The visual distraction of the "little car"



When the **NEW** or **RETEST** key is pushed and the "little car" visual distraction option is "on" (press **SELECT** to change to tympanometer graph as opposed to car), the above graphic will be displayed on the screen.

When a proper probe seal is obtained and the test is in progress, the "little car" will move from the left to the right of the screen and the "garage door" will open:





# Operating Instructions

## Quik Tymp<sup>®</sup> 1 (MI 20), Quik Tymp<sup>®</sup> 2 (MI 21)

A successful tympanometry exam will result in the "little car" ending in the garage.

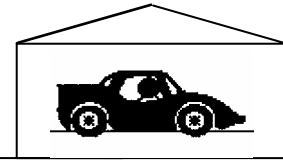

When the "little car" is parked in the garage and the door closes, the screen will then display the completed graph:

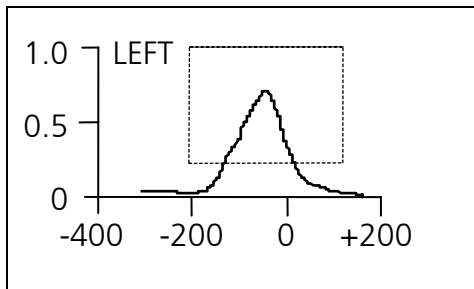

COMP PK 0.6 cc  
PRS PK -13 daPa  
EAR VOL 1.0 cc  
GRAD-TW 103 daPa

2) The visual display of the graph

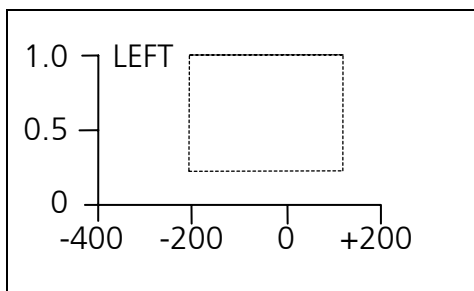

When the visual distraction option is turned "off", and the **NEW** or **RETEST** key is pushed, the above graphic will be displayed on the screen. When the test is completed, a completed graph will be shown.



# Operating Instructions

## Quik Tymp<sup>®</sup> 1 (MI 20), Quik Tymp<sup>®</sup> 2 (MI 21)

### 7.0 THE TYMPANOGRAM

The Quik Tymp 1 and Quik Tymp 2 can display and provide a printed report that is a graphic representation of the mobility of the eardrum. This is called a tympanogram.

Please note that tympanometry is a test of middle ear function only. A “normal” functioning middle ear does not mean “normal” hearing. It is possible to be completely deaf and still have a normal tympanogram.

#### 7.1 NORMAL TYMPANOGRAMS

Normal tympanograms do not look exactly alike, but they have some common characteristics:

- 1) There is a “peak”
- 2) The “peak” generally falls somewhere between +50 daPa and -150 daPa

The following is an example of a “normal” tympanogram:

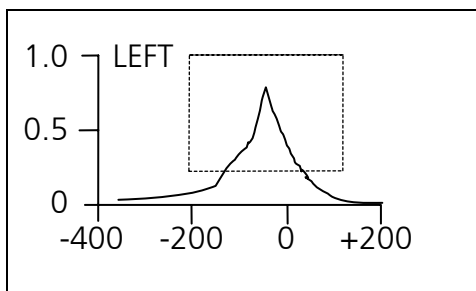

#### 7.2 ABNORMAL TYMPANOGRAMS

Abnormal functioning of the middle ear system will be reflected in the tympanogram. The following are examples of common abnormal tracings.

- **Type B**

The following diagrams show a variety of Type B abnormal tympanograms. The characteristics of a Type B tympanogram are:

- 1) There is no “peak”
- 2) The tympanogram tracing is (primarily) flat

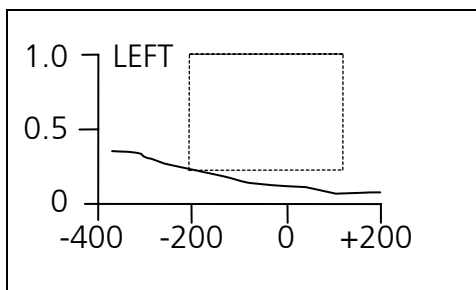



# Operating Instructions

## Quik Tymp<sup>®</sup> 1 (MI 20), Quik Tymp<sup>®</sup> 2 (MI 21)

The shape of the tympanogram in these tracings may be indicative of a variety of different ear disorders including:

1. Fluid in the middle ear space
2. Severely retracted Tympanic membrane
3. Perforated Tympanic membrane
4. Complete blockage of the external canal with wax or debris
5. The presence of a ventilation tube in the Tympanic membrane

- **Type C**

Type C tympanograms may indicate a retracted Tympanic membrane. They exhibit a peak on the left side of the graph or at a point more negative than -200 daPa. The height may vary from normal, indicating different degrees of mobility.

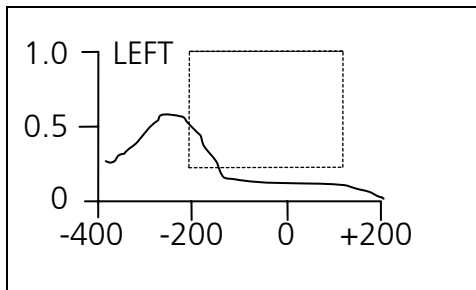

- **Type A<sub>s</sub>**

Type A<sub>s</sub> tympanograms may indicate normal middle ear pressure, but limited mobility. The shape is the result of very small changes in compliance. The “stiff” middle ear system may be indicative of pathology. However, it may be considered normal in young children or patients with a thickened or heavily scarred membrane.

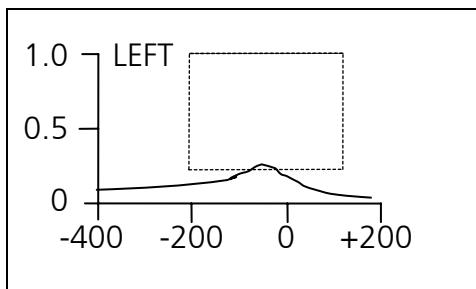



# Operating Instructions

## Quik Tymp<sup>®</sup> 1 (MI 20), Quik Tymp<sup>®</sup> 2 (MI 21)

### 8.0 FREQUENTLY ASKED QUESTIONS

#### 8.1 HOW DO I LOAD THE PAPER ROLL?

Your unit is equipped with an **automatic feed printer**. The unit has a 4" thermal paper roll that allows for 70 tympanometer (both right and left ear) and audiometer readings.

- 1) Turn the power "ON". After unit is powered up, depress the **NEW** key as if you were going to begin an exam.
- 2) Open the door on the front of the unit (paper cradle).
- 3) Gently remove the remaining paper and spool from paper cradle and discard (see "Removing old paper roll" for instructions).
- 4) Remove the tape from paper roll and discard any portion of paper that has the tape or adhesive still on it. If necessary, cut off any portion of paper roll with adhesive. If you must cut off excess paper, cut it in a *straight line*. You do not have to cut into a "v" shape.
- 5) Unroll 6-7 inches of paper from roll.
- 6) Load paper in a downward direction and insert the paper under the printer roll. Once the printer "eye" recognizes the paper, the unit will **AUTOMATICALLY FEED THE PAPER** under the paper roll. This happens very quickly.

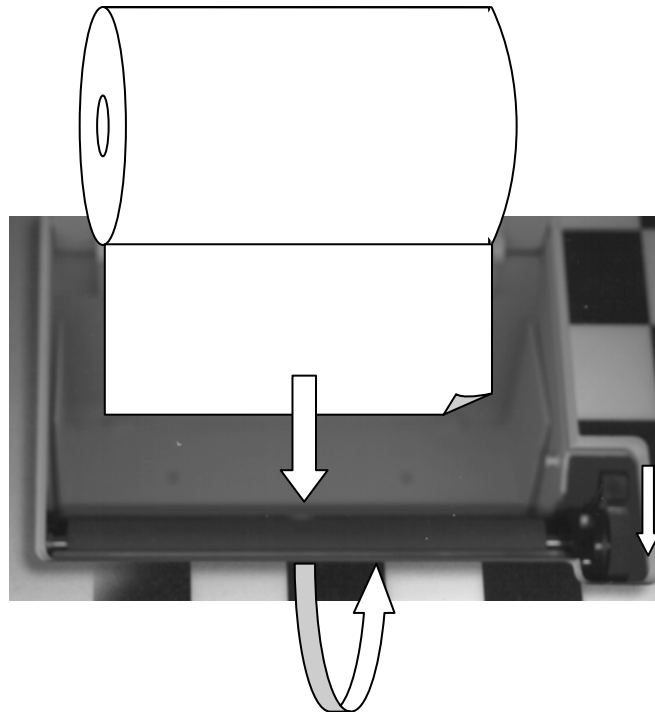



# Operating Instructions

## Quik Typ<sup>®</sup>1 (MI 20), Quik Typ<sup>®</sup>2 (MI 21)

- 7) Once the unit has fed the paper, gently roll any excess paper onto the paper roll and place paper roll into the paper cradle. The paper roll will fit securely into the cradle and the paper should be rolling out from under the paper roll.

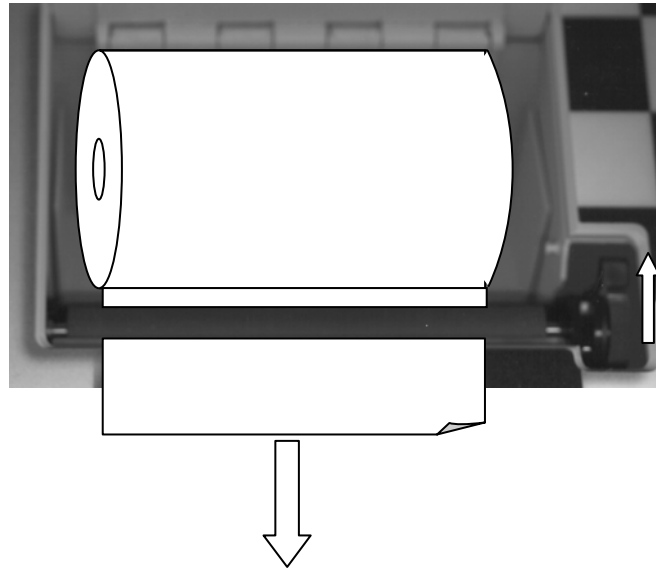

### 8.2 REMOVING OLD PAPER ROLL

- 1) Move the head lever (on the right side of the paper guide) to its release position (towards the front of the unit)
- 2) Gently remove the remaining paper and spool from paper cradle and discard.
- 3) Move the head lever back into its lock position (towards the rear of the unit).

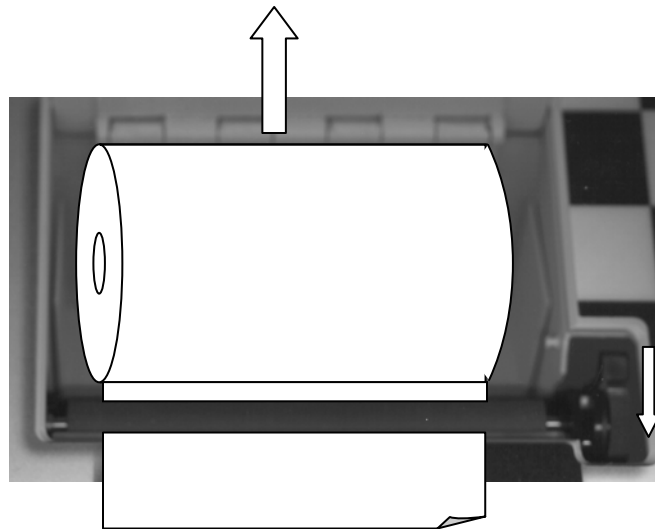



# Operating Instructions

## Quik Tymper<sup>®</sup> 1 (MI 20), Quik Tymper<sup>®</sup> 2 (MI 21)

---

### 9.0 ROUTINE CARE

#### 9.1 CARE OF THE UNIT

Always unplug the power supply module from the wall outlet before attempting to clean the unit. Clean the unit by applying a mild detergent to a damp soft cloth. Use caution around the connector area. The unit should be stored at room temperature. A "cold" unit should be allowed to warm up for 10 – 15 minutes, to room temperature, before operating. DO NOT IMMERSE IN WATER!

#### 9.2 CARE OF THE TYMPANOMETER PROBE

Handle the probe with care and **DO NOT DROP!** DO NOT USE ALCOHOL TO CLEAN THE PROBE. Alcohol will damage the components of the hand held probe.

Proper maintenance of the hand held probe would include periodic cleaning of the probe cone. To remove debris (wax and dirt), first remove the rubber ear tip then, gently unscrew the cone counter clockwise. To clean the cone, pull a pipe cleaner through the opening. Do not pull the pipe cleaner back and forth, as this may redeposit debris on the wall of the cone. When clean, return the cone back to the probe head by slowly turning clockwise.

#### 9.3 CARE OF THE EAR TIPS

Your unit includes a set of 6 eartips:

- 2 blue (pediatric)
- 2 white (infant)
- 1 gray (medium adult)
- 1 red (large adult)

For sanitary purposes, your eartips should be disinfected after every tympanometry exam.

- 1) ALWAYS remove eartip from probe before cleaning eartip.
- 2) Using an alcohol pad, gently wash off the eartip. If any wax is inside the center of the eartip, use a pipe cleaner to remove the wax from the inside of the eartip.
- 3) WAIT UNTIL EARTIP IS COMPLETELY DRY BEFORE PLACING IT BACK ONTO THE PROBE. The fumes in the alcohol will disable and possibly destroy the probe if the eartip is not completely dried.

#### 9.4 CARE OF THE AUDIOMETER HEADPHONES- QUIK TYMP 2 (MI 21)

Handle the headphones with care. When storing do not wrap wires around the headpiece. If necessary the ear cups can be cleaned with a cloth dampened in mild detergent. Do not "wet" the inside portion of the ear cups, it will effect the proper operation of your audiometer.



# Operating Instructions

## Quik Tymp<sup>®</sup> 1 (MI 20), Quik Tymp<sup>®</sup> 2 (MI 21)

---

### 9.5 CALIBRATION OF THE INSTRUMENT

The optimum length of time between re-calibrations for audiometers varies, depending upon the treatment given the instrument and the headphones. It is recommended that the instrument have a laboratory calibration at least once every year. Since rough handling, such as dropping the headphones, can easily cause calibration errors it is advisable to establish a biological calibration check as soon as you receive the instrument.

Should you feel at a later date that the audiometer's calibration might be in error, perform a biological check on a known ear. If all re-tests show major changes, calibration is probably in error.

All repair and re-calibration should be done at an authorized Maico Special Instruments Distributor service center. This assures the use of quality materials by trained and experienced technicians using the proper, accurate equipment.

Maico Special Instruments Distributors are located in major cities throughout the world. To minimize costs and time delays, contact the Distributor that you purchased the instrument from. If you don't know who that is, or need to find the Distributor closest to you, contact the factory at:

Maico Diagnostics  
7625 Golden Triangle Drive  
Eden Prairie, MN 55344  
Toll free 888-941-4201  
Phone 952-941-4200  
Fax 952-903-4200

Customers outside of North America and South America may contact:

Maico Diagnostic GmbH  
Salzuffer 13/14  
10587 Berlin, Germany  
phone ++030 70 71 46 50  
fax ++030 70 71 46 99



# Operating Instructions

## Quik Tym<sup>®</sup>1 (MI 20), Quik Tym<sup>®</sup>2 (MI 21)

---

### 9.6 SHIPPING INSTRUCTIONS FOR RE-CALIBRATION AND REPAIR

In the event it becomes necessary to return the instrument for re-calibration or repair, please follow these instructions:

1. Place the instrument in the original shipping carton, using the packaging provided. Be sure to include all accessories, as they are required for proper calibration.
2. Enclose an explanatory letter describing the service you require, carefully detailing any operational problems. Be sure to include your name, phone number, the serial number and your full return address for return shipping.
3. Ship prepaid to your Maico Special Instrument service center.

**NOTE:** Warranty service is provided by your authorized Maico Special Instruments Distributor.

**DO NOT ATTEMPT TO REMOVE THE INSTRUMENT CASE YOURSELF. THIS SHOULD BE DONE ONLY BY AN AUTHORIZED MAICO SERVICE TECHNICIAN.**

